

# Quick Start

Keo Blade Power  
X-Track Power



# Quick Start

1

Download the Application and follow the instruction provided within the application.

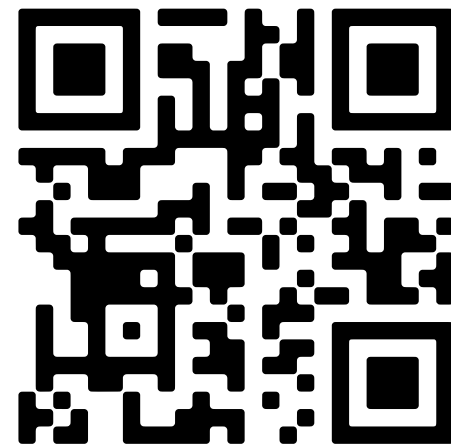

Keo Blade Power  
X-Track Power

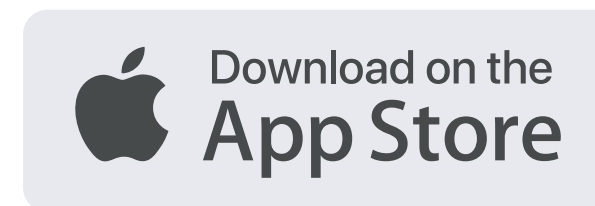
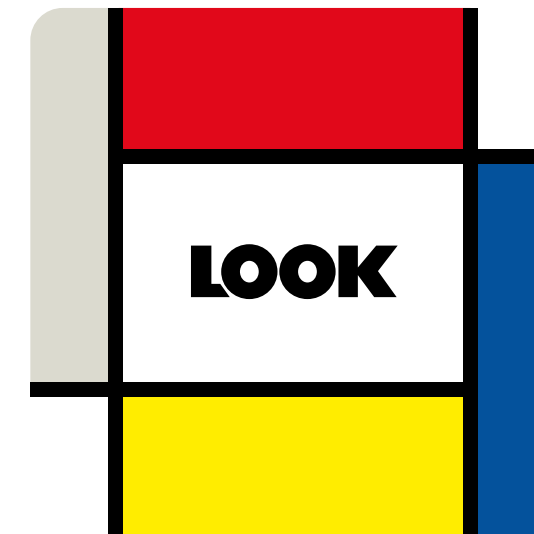

## Quick Start \_\_\_\_\_

# 2

Fill in your profile.

Keo Blade Power

X-Track Power



# 3

Add your power meter to your product ecosystem.

Keo Blade Power  
X-Track Power



## Quick Start

# 4

Turn on your pedals by charging them for few seconds until the pedals flash (1 in Single / 2 in Dual ).

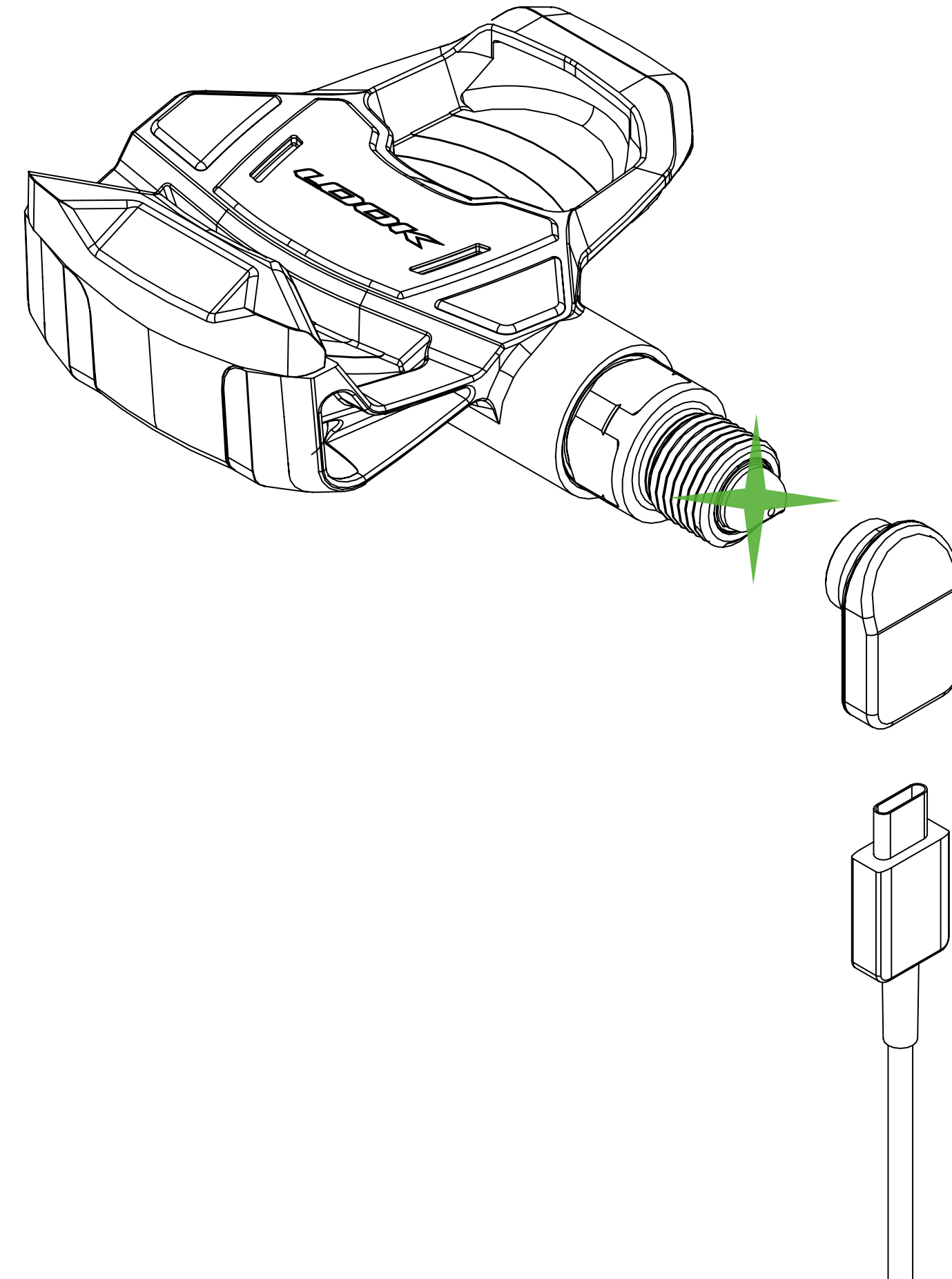

Keo Blade Power

X-Track Power

**LOOK**

# 5

Using a 15mm open-end wrench, tighten your pedals to 30 Nm:

- clockwise for the right pedal.
- counterclockwise for the left pedal

The left pedal is marked with a ring on the axle (located in the position to tighten the pedals).

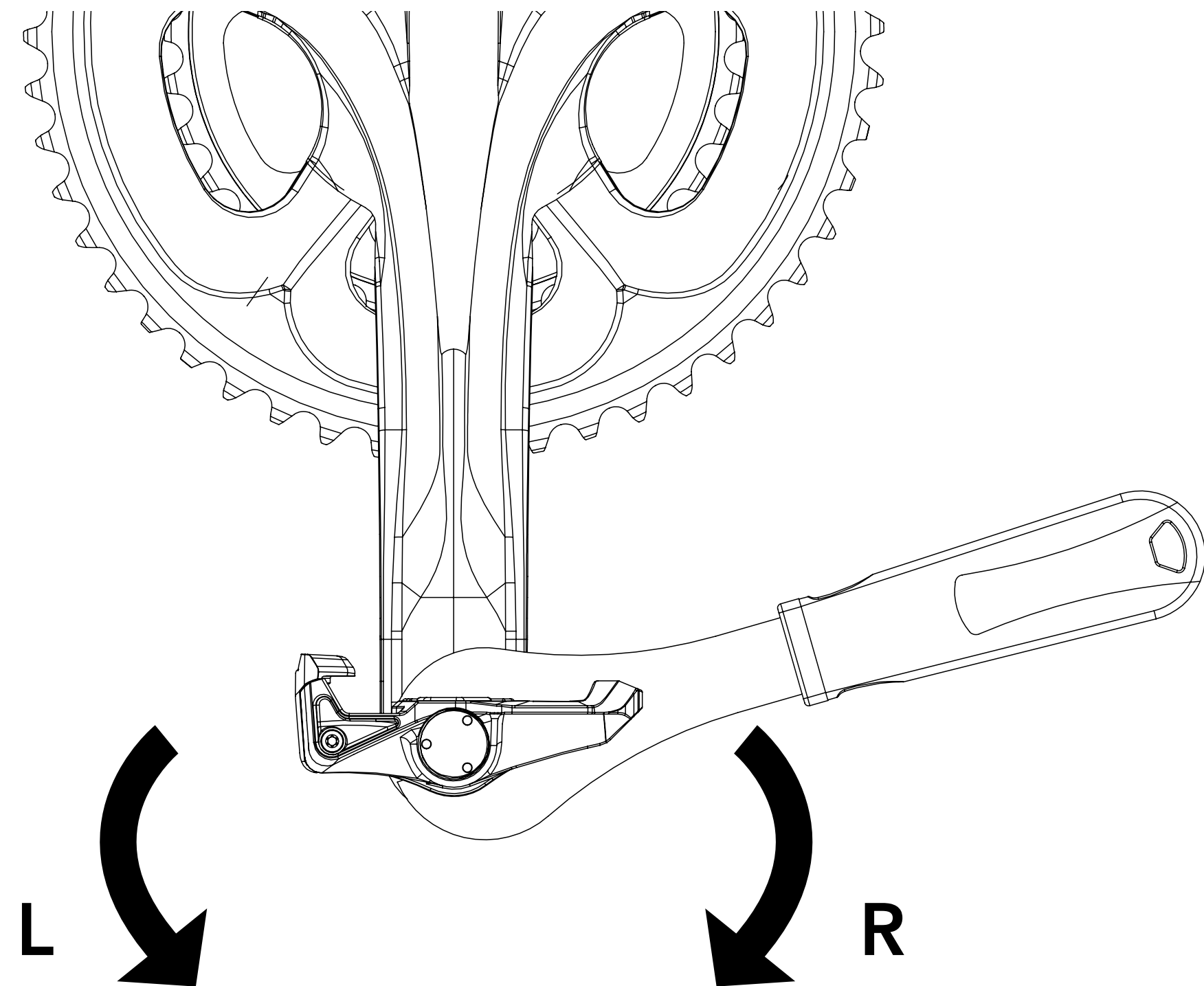

# 6

### Pair the pedals with the app.

- Make sure your pedals are turned on by turning the cranks back and forth before connecting them to the app.
- You only need to pair the «master» pedal in a dual set. The «slave» pedal will not appear.

Keo Blade Power

X-Track Power

# 7

Register your warranty in the app.  
(To get an **extended 3 years warranty**).



## Quick Start

8

Set the crank length in the app.

9

Perform pedal calibration in the app.  
(Remove your feet from the pedals and do not move them during calibration).

Keo Blade Power

X-Track Power

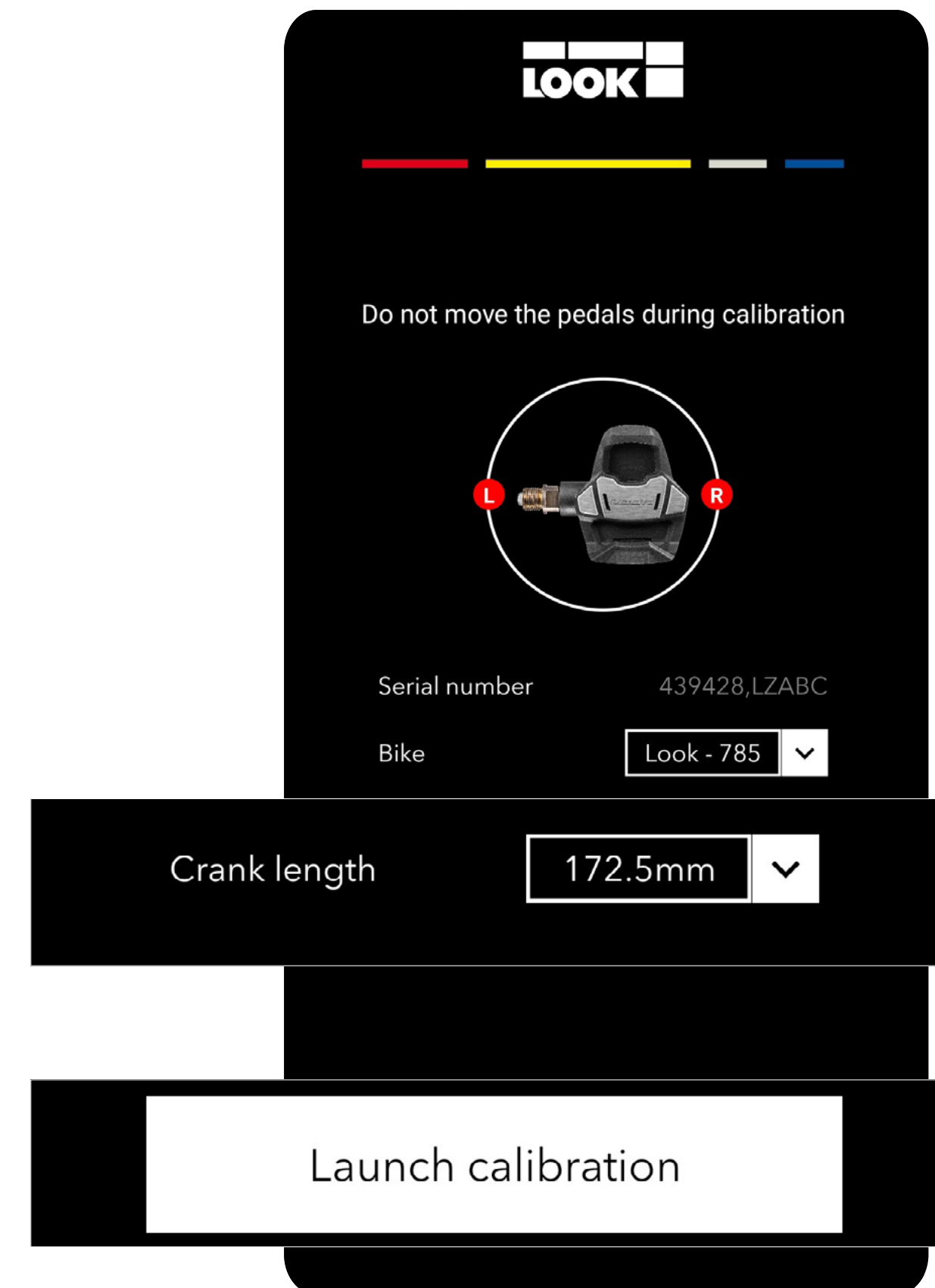



# 10

Mount the Keo/X-Track cleats on your shoes.

Keo Cleat

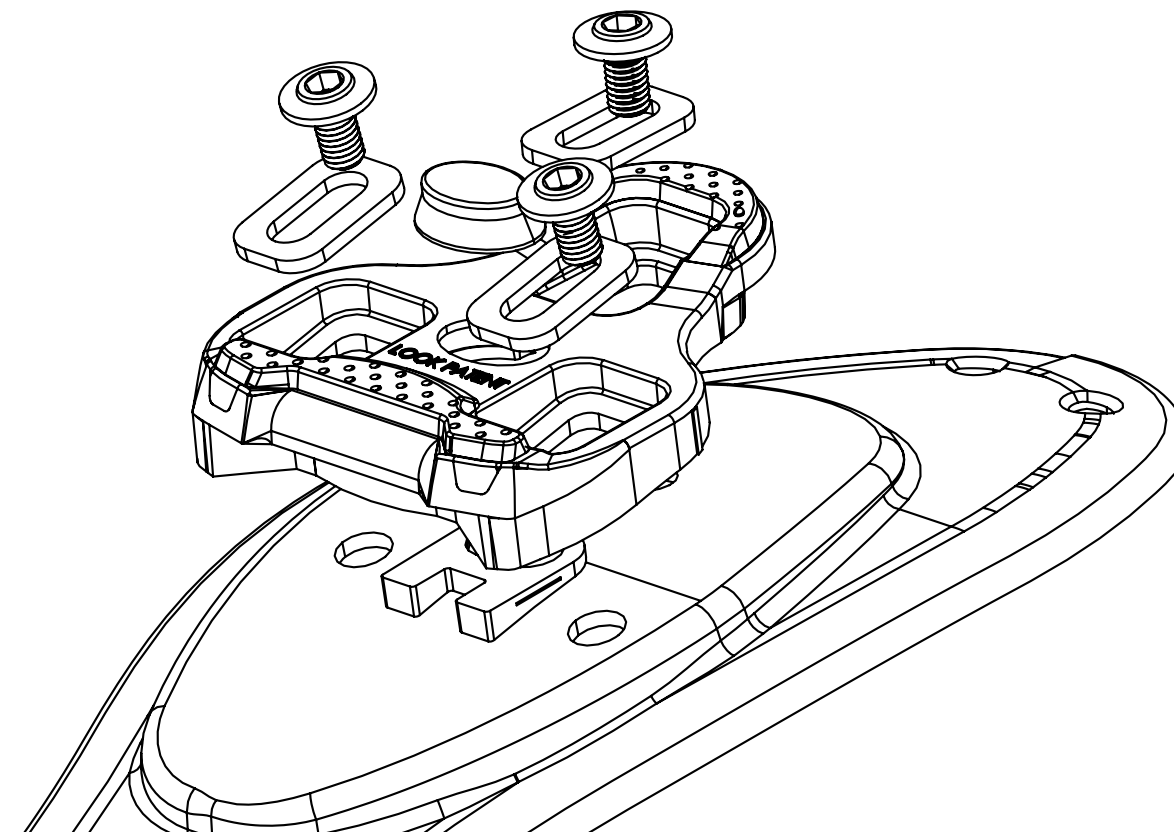

X-Track Cleat

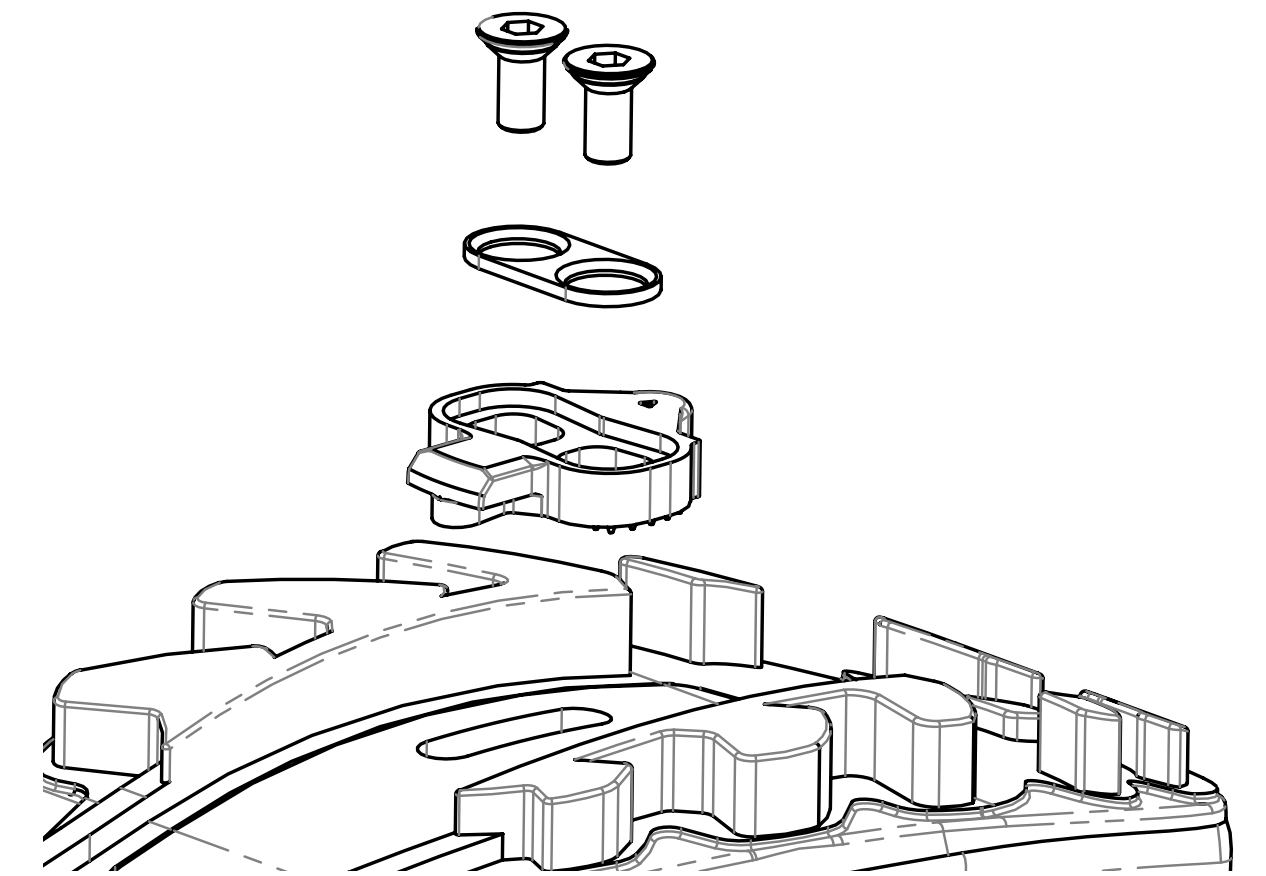

# 11

**Pair the pedals with your cycling computer/  
watch.**

**A/** Connect your pedals to your computer. (refer to your bike computer manual - **Be cautious:** not all computers/watches are compatible with power meters).

Once the pedals are connected, you should:

**B/** Set the crank length on your computer.

**C/** Perform a calibration ('zero offset') the sensor.»

- Set your crank length in your cycling computer. Please refer to the manual of your device (ensure that the values entered in the application match those on the computer).
- We recommend to do a zero offset before each ride.



Quick Start \_\_\_\_\_

**Enjoy your new power meter!**

Keo Blade Power

X-Track Power

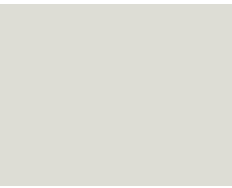

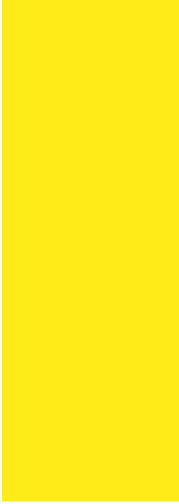

The Art ———  
Of Cycling

**LOOK**