

795 Blade^{RS} 3

White Paper



Real Roads.
Real Wins.
You.
Faster.

Strictly embargoed until June, 30th 3^{PM} CET.





Table Of Contents

Introduction

Mission statement	4
Philosophy	5

Part 1

Real World Gains

CFD Work	10
Aerodynamic Development & Testing Process	11
Aero Gains	12
Power-to-weight	15
NEW Aero Carbon ^{RS} 3 bar	17

Part 2

Custom Performance

Fit & Adjustment Options	22
Components & Geometry	24
The configurator «Your LOOK à la Carte»	29

Part 3

Unique Riding Experience

Crafted in Burgundy	32
Same Bike. No Exception.	34
Contact	35

The Truth Is On The Road.

Wind tunnels tell one story.
The road tells the truth.

The **795 Blade^{RS} 3** was built for the truth.
For the last hour.
For the breakaway.
For the headwind that won't quit.

890 grams of obsession.
350 ways to make it yours.
40 years of racing in every detail.
Handcrafted in Burgundy.
Raced - and won -
before you ever heard its name.

The same bike the pros ride.
No compromise.
You bring the legs.
We bring the bike.

**Real roads.
Real wins.
You.
Faster.**



Mission Statement.

One obsession:

The **795 Blade^{RS} 3** was born from a single obsession: making you faster, everywhere it counts.

The third generation of the 795, our racing bike:

- The proven **795** geometry, carried over - the handling you already trust
- **NEW** handlebars and **Aeropost 5** seatpost
- 350 ways to fit - more adjustment than ever

A fully redesigned frame:

15W aero drag, 160g lighter* (vs the previous **795 Blade^{RS}**)

Complete bike from 6.9 kg

(Size M, without pedals)

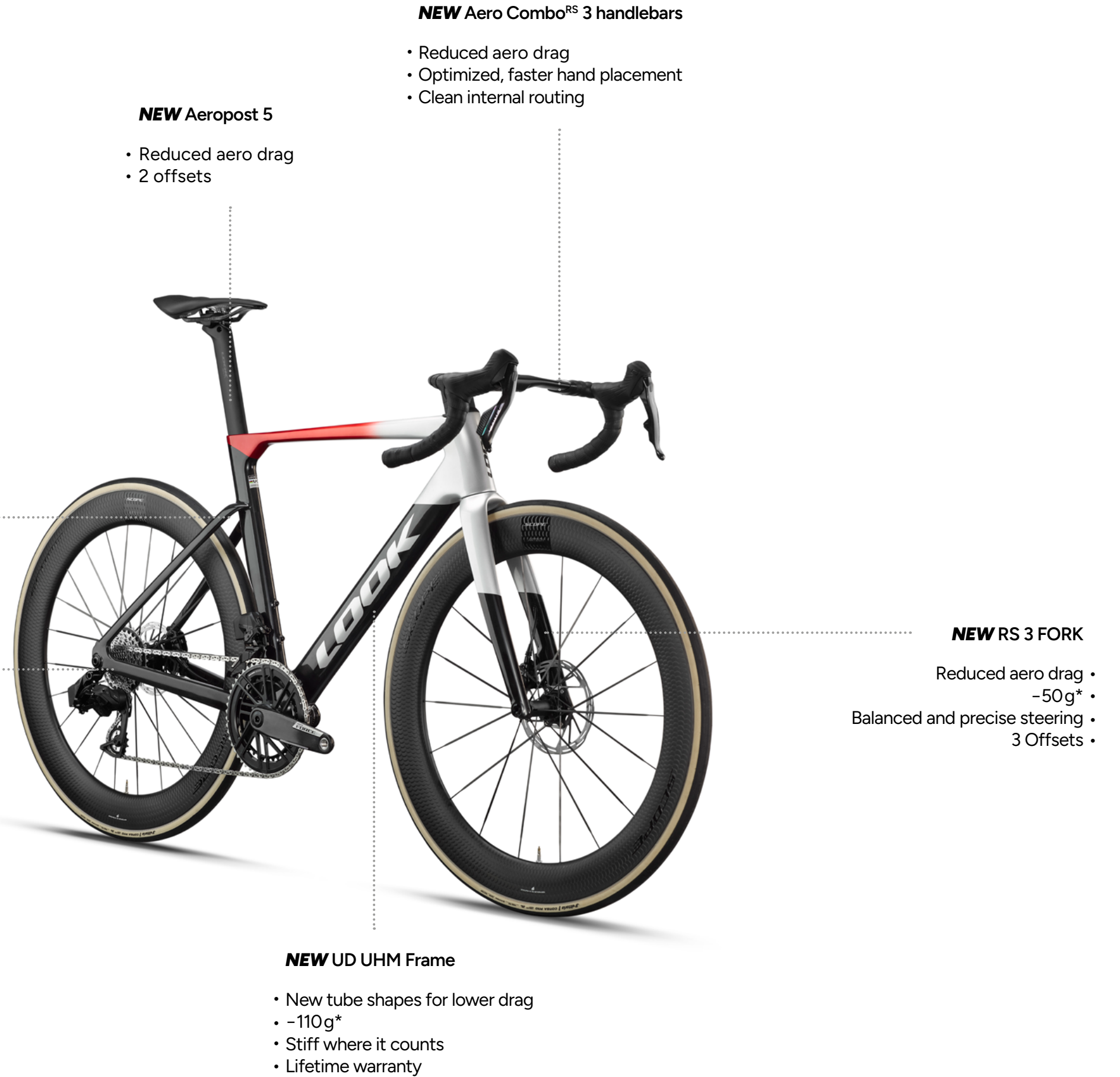

NEW Aero Combo^{RS} 3 handlebars

- Reduced aero drag
- Optimized, faster hand placement
- Clean internal routing

NEW Aeropost 5

- Reduced aero drag
- 2 offsets

34mm tire clearance

- Front and Rear

UDH Frameset:

- 890 g frame (M)
- 340 g fork

NEW RS 3 FORK

- Reduced aero drag
- -50g*
- Balanced and precise steering
- 3 Offsets

NEW UD UHM Frame

- New tube shapes for lower drag
- -110g*
- Stiff where it counts
- Lifetime warranty

* ** SIZE M AVERAGE, PRO TEAM BLACK - TOLERANCE +5/-5%

Your Fastest Ride, Engineered.

The 795 Blade^{RS} 3 was built for one obsession: speed you can feel and gains you can measure.

Advanced aerodynamics and an 890g painted frame deliver supreme handling and instant & exciting power transfer - every watt going straight to the road.

Six sizes, each with its own geometry. Over 350 ways to fit.
A pure race-bred road bike, developed for every rider and handcrafted in Burgundy.





Part 1

Real-World Gains

Where gains get real.

Wind tunnels tell one story.
The road tells the truth.

The **795 Blade^{RS} 3** is built on LOOK's holistic-gain philosophy : aerodynamics, lightness and power transfer in harmony.

But lab numbers only matter if they hold up where it counts. So we took the prototype out of the lab and into real conditions, chasing gains you can feel: in the breakaway, on the climb, into a headwind, at kilometre 180.

Every rider, every road, every race.
One purpose: making you faster.

Part 2

Custom Performance

Part 3

Unique Riding Experience

**It's Not Just
A Faster Bike.**

205W

Estimated Normalized
aero drag.

*Estimation according to Tour Magazin protocol,
based on internal data.*

-15W

Compared to its predecessor (50 kph).
LOOK Data

**It's Designed
To Make You Faster.**



CFD Work

Reduced Aero Drag.

Every tube section has been individually optimized to meet specific aerodynamic and structural objectives.

The ideal shape varies significantly depending on its position on the bike. At the front, where priority is given to low drag and stiffness, tubes are shaped to cut through clean, undisturbed air. At the rear, where the goal is to manage the turbulence generated by the rider, the tubes are thinner and more compliant.

The result is an integrated bike design that works as a complete system, where every element is engineered in relation to the others, and performance is maximized across the board.

795 Blade^{RS}

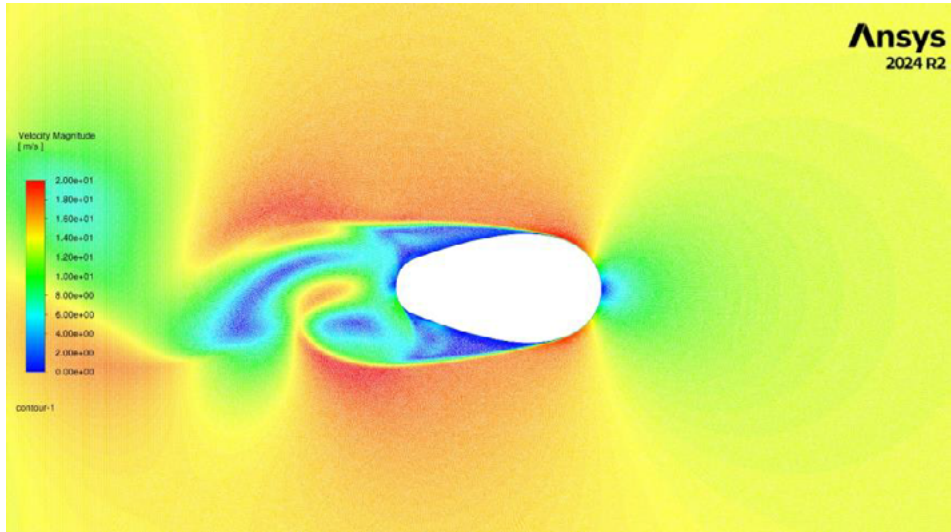

NEW 795 Blade^{RS} 3

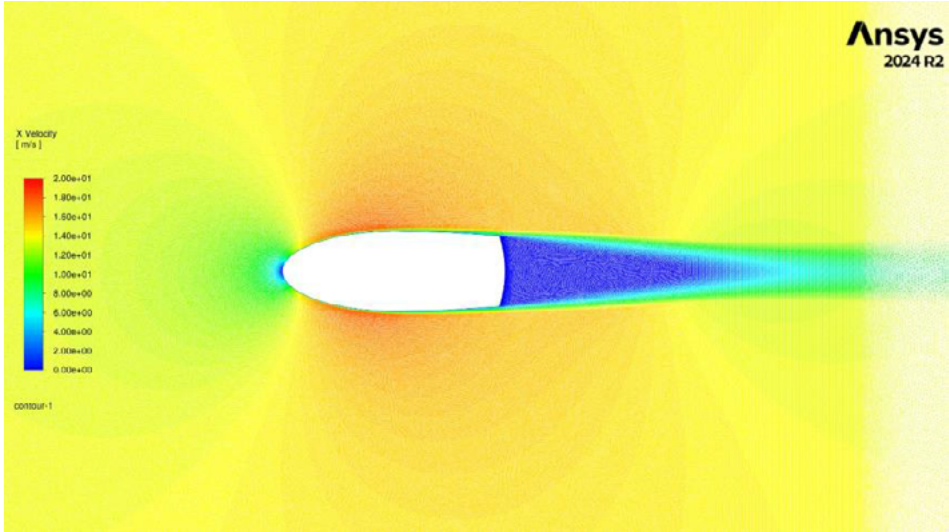

0°



5°



10°

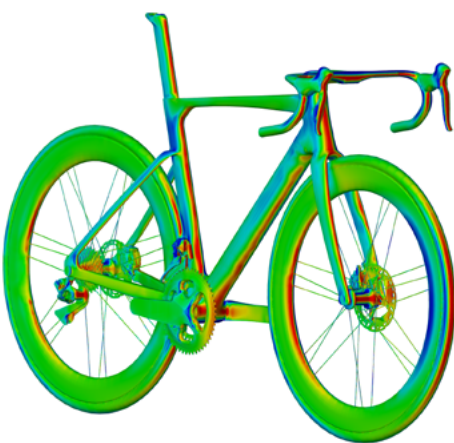

15°

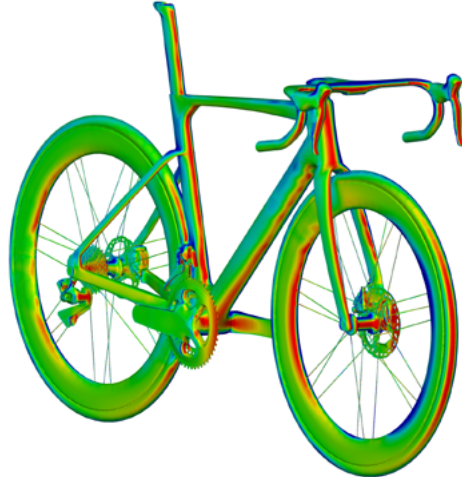

From a 0° to 15° yaw angle, the aero drag remains steady and reduced to areas where loss is unavoidable.

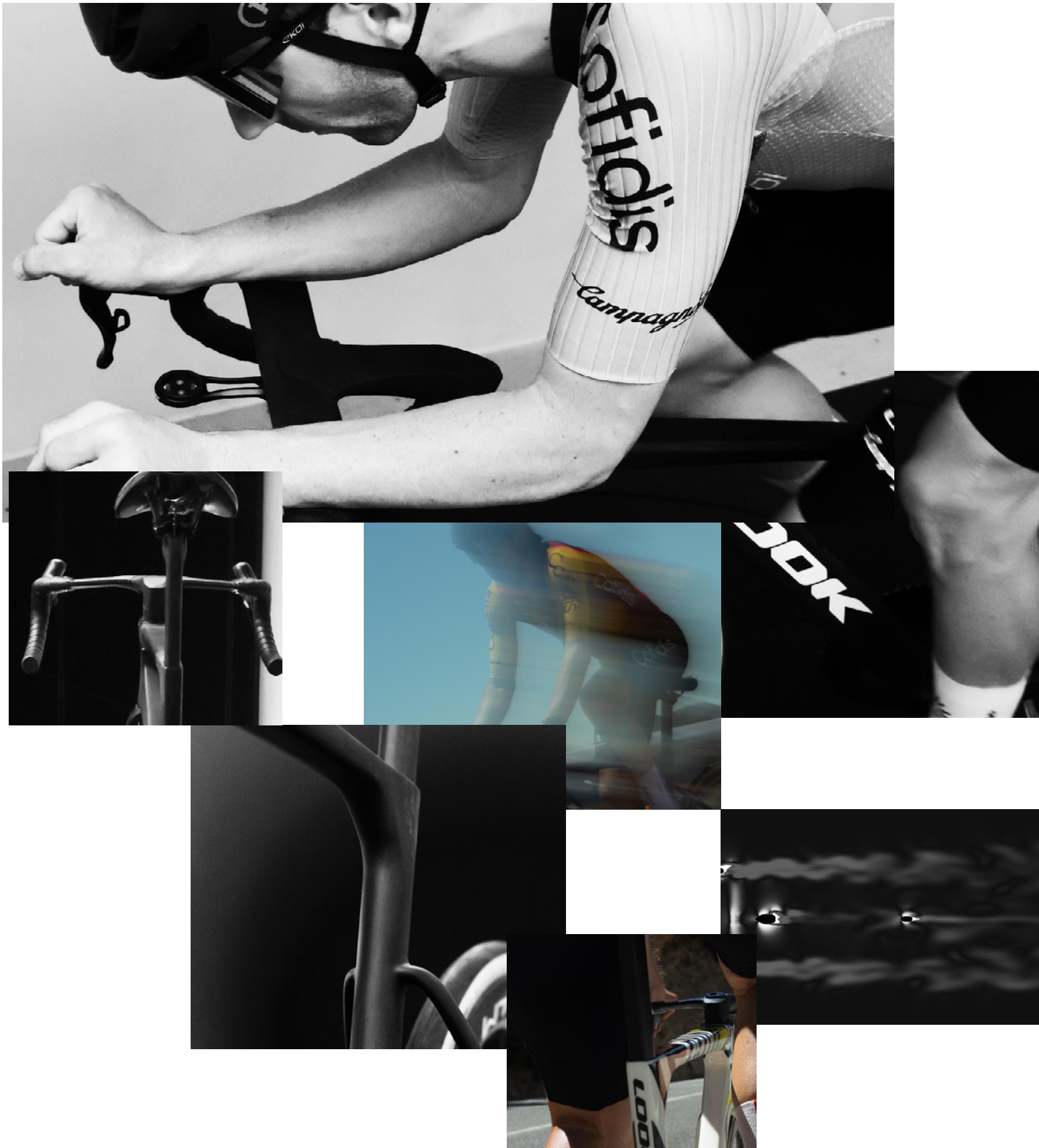

Aerodynamic Development And Testing Process.

LOOK's aerodynamic development philosophy has evolved a lot in the past 3 years, and with it, the tools and processes used to achieve our goals.

Our philosophy is based on two core principles:

- Aerodynamic optimization that works in the real world: unsteady air, turbulence, high yaw angles.
- Aerodynamic optimization that works with – and for – all the riders: we want to understand all our choices, so they are not a “bike alone” testing artifact or a statistical fluke when testing with a human or a dummy.

The optimization that happens in CFD simulations allows us to explore various geometries without making prototypes, which can be sometimes more convenient and faster. It also allows us to understand the flow characteristics more deeply in comparison to the wind tunnel, which gives a drag value but does not allow the same level of flow visualization. At the CFD optimization stage, the emphasis is already put on high yaw angles as a way to ensure that the gains exist in the real world.

The next step is the wind tunnel, where the bike is tested alone to have baseline data. Of course, real performance happens only with a rider on the bike, so the rider must come in at some point.

However, we are very careful with the way we conduct experiments and draw conclusions: testing with a rider (or even a dummy) introduces biases and noise, so we cannot do without robust setup and statistical analysis. We control the rider position as best as possible, test with different morphologies and repeat the tests enough to characterize the experimental noise at each yaw.

A new solution is considered better if the performance improvement is bigger than the experimental noise. This is a very high bar to pass, but it is the mission we gave ourselves: to make anyone who rides a 795 Blade^{RS} 3 faster, all the time.

The final step is the real-world validation in a velodrome or on the road. It is of course more difficult to control than a wind tunnel environment, but this is what counts to win races.

Aero Gains.

The **795 Blade^{RS} 3** brings cutting-edge aerodynamics with a smart, results-driven approach. The real breakthrough isn't the headline number at zero degrees; it's how the bike behaves when the road turns unpredictable.

Yaw angles, crosswinds, side gusts, turbulence : all built into our development, because the wind never blows at zero degrees and the peloton never rides in a vacuum.

And the biggest part of any aero system is the rider. The wide range of fitting possibilities helps every rider find the position that reduces drag - and holds it steady, kilometre after kilometre.

The result is a bike that stays one wheel ahead, whatever the road throws at you.

The Wind Never Blows At 0°.

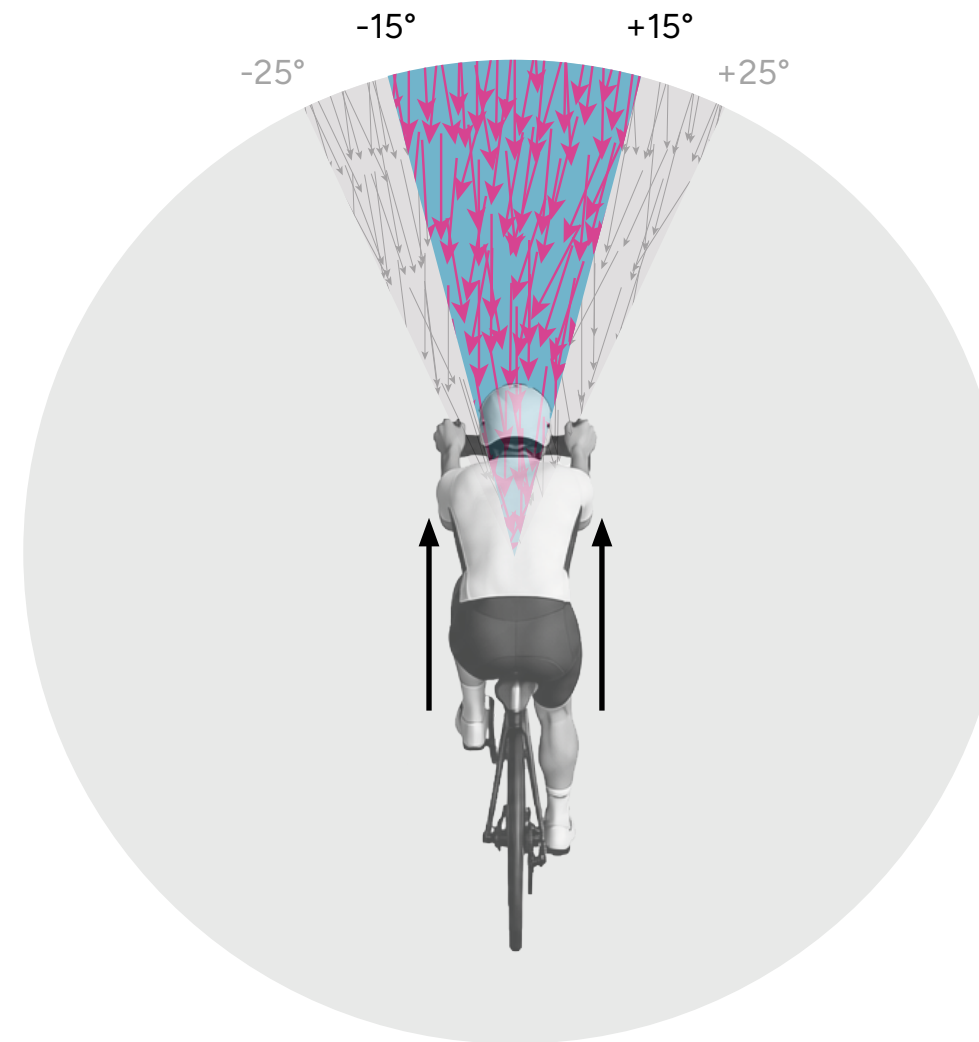

The performance of the **795 Blade^{RS} 3** at every yaw angle tested is fundamental when pursuing real world gains. In racing conditions, the wind impact is not controlled and changes often and quickly.

We focused on offering a consistent, tangible aerodynamic gain whatever the configuration and yaw angle tested, to maximize the chances to make a difference on race day.

TIME SPENT AT EACH YAW - WIND 3.0 M/S FROM 33° (NNW)
ON A ROLLING TEST COURSE RIDDEN AT 34KPH AVG

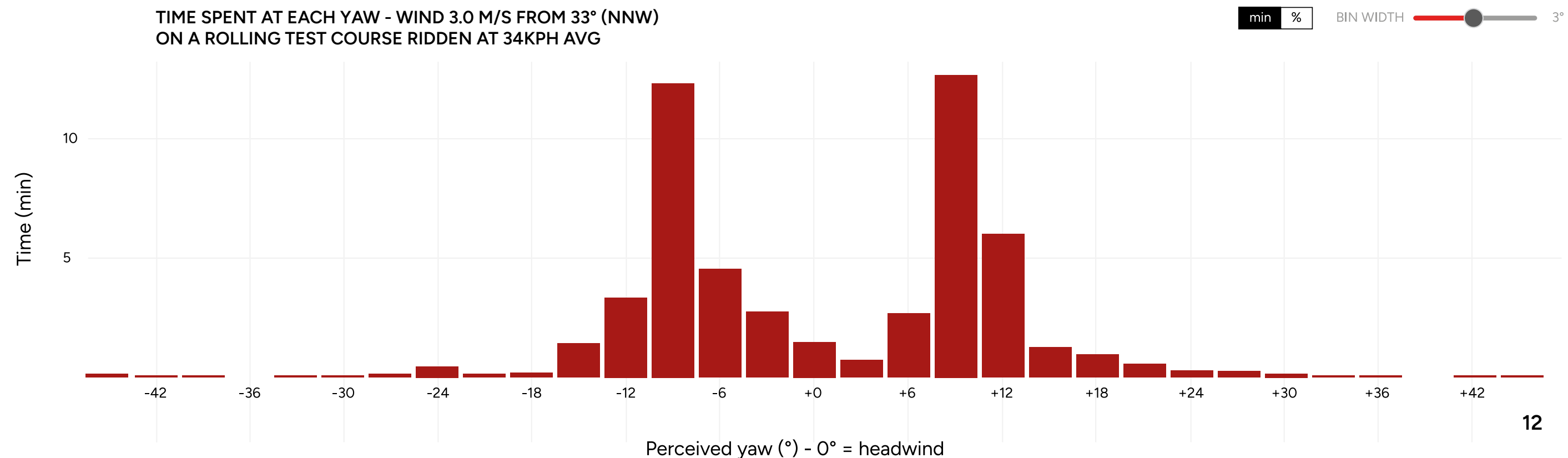

The aerodynamic advantage of the new **795 Blade^{RS} 3** over the **795 Blade^{RS}** remains remarkably consistent, whether tested with or without a rider.

The **795 Blade^{RS} 3** provides a 15W aerodynamic saving for the complete bike-and-rider system.

This aerodynamic gain confirms the effectiveness of optimizing the rider-bike system as an integrated whole, accounting for rider-machine interactions to deliver improved real-world performance.

-15W

Compared to its predecessor (50 kph).
LOOK Data

RAW POWER - Bike alone

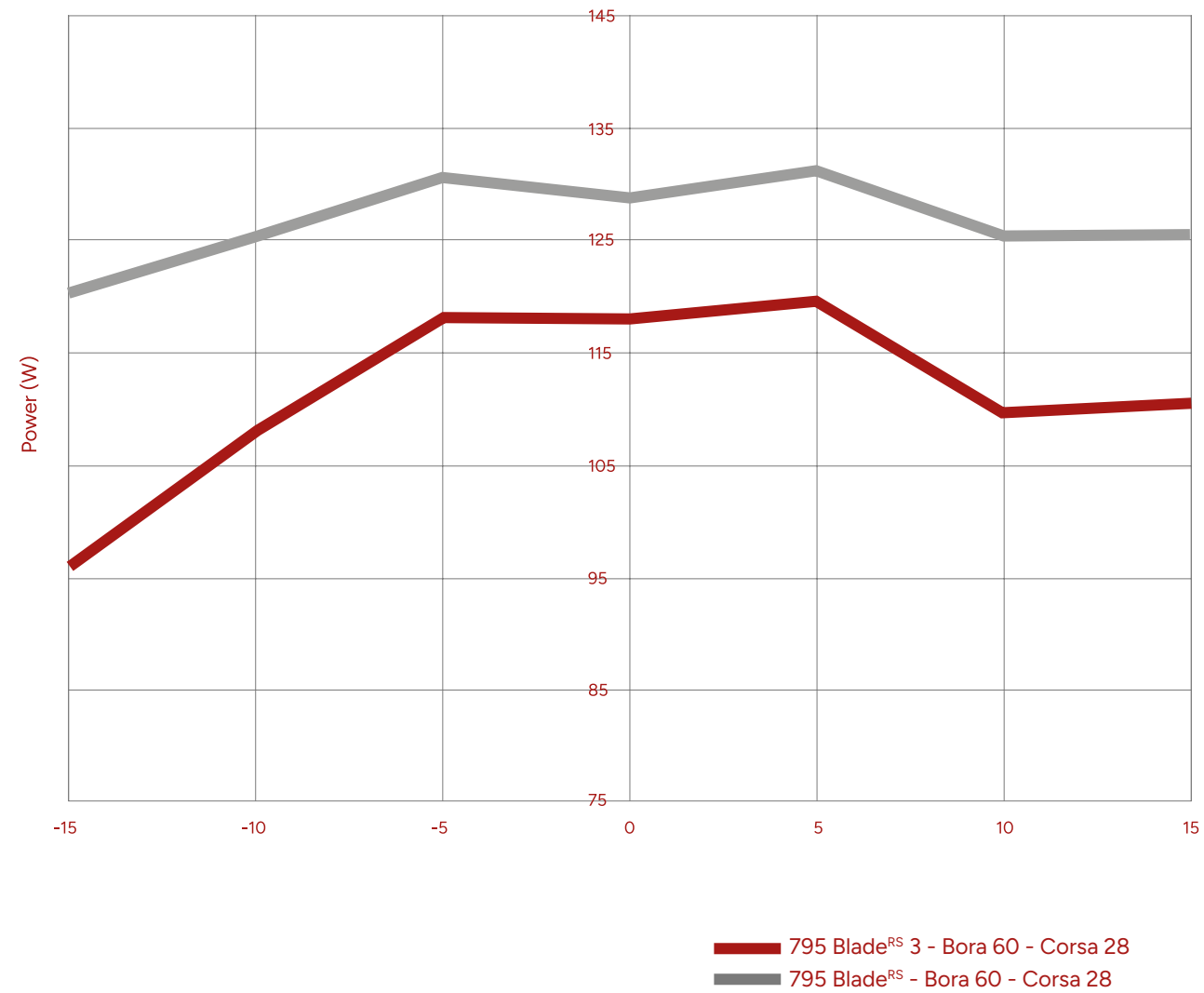

RAW POWER - Bike + Rider

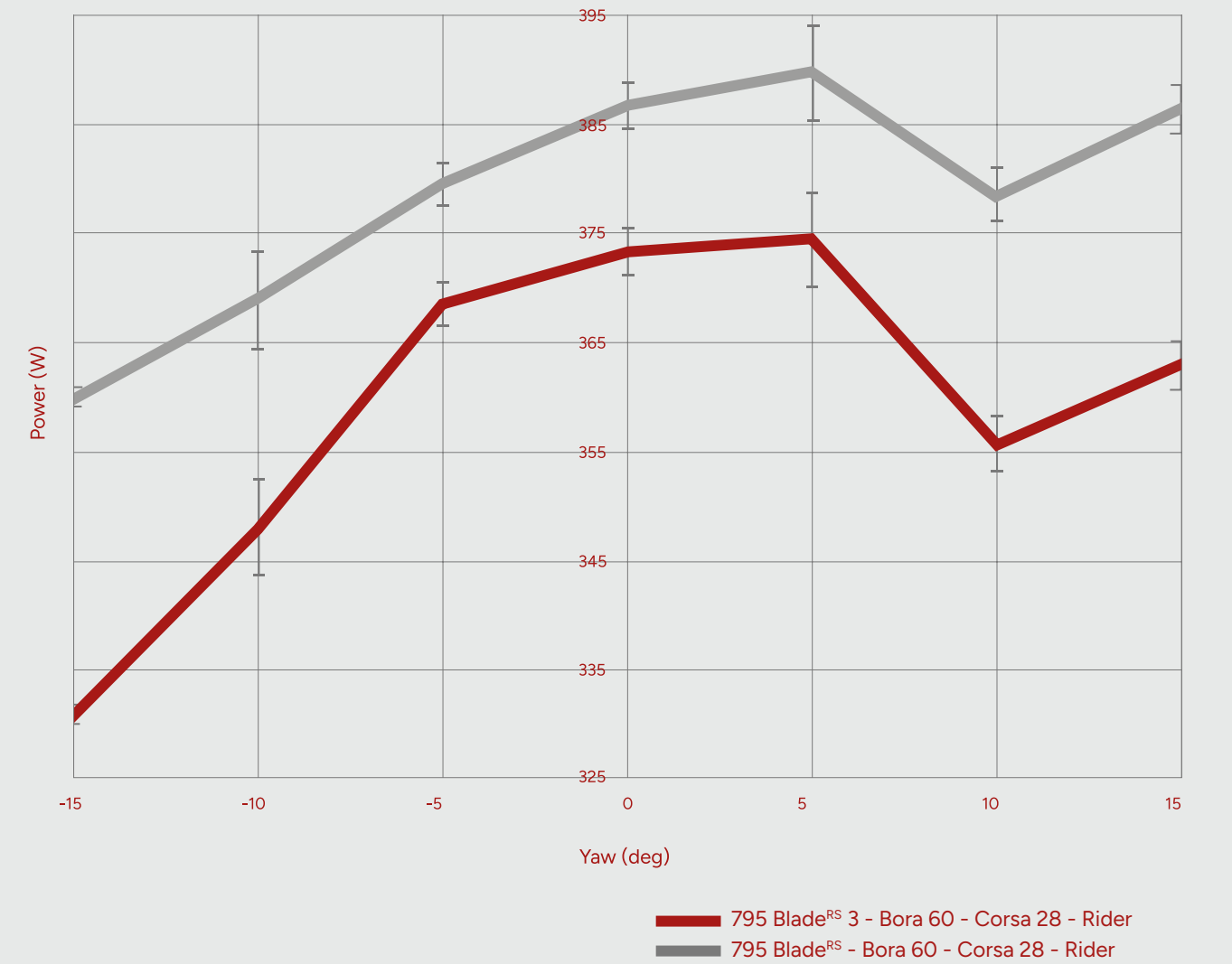



A Riding Experience Made Of Supreme Efficiency, On The Flat Roads, In The Climb And Downhills.

Every Watt, Delivered.

The legendary feel of a LOOK racing bike comes from one balance:

Stiffness placed with intent, and purposeful lightness.

Where it matters most - the bottom bracket and the head tube - the **795 Blade^{RS} 3** is 10% stiffer than the World Tour average, so every watt drives the bike forward and every input lands precisely.

Everywhere else it stays compliant: the patented flexible seatstays, increased flexibility of the fork and the 34mm tyre clearance work in unison so the road stays quiet under you.



Fork weight :
340g

Frame weight :
890g
(Size M)

Stiff in the areas that deliver your power to the road, compliant where comfort and rolling efficiency matters.

One Bike Every Advantage.

- **Backed For Life**
Lifetime warranty,
frame & fork
- **Proven In The Peloton**
Built to keep racing,
season after season
- **Cockpit & Seatpost
Included, Engineered As One**

Aero Bike



Lightweight Bike

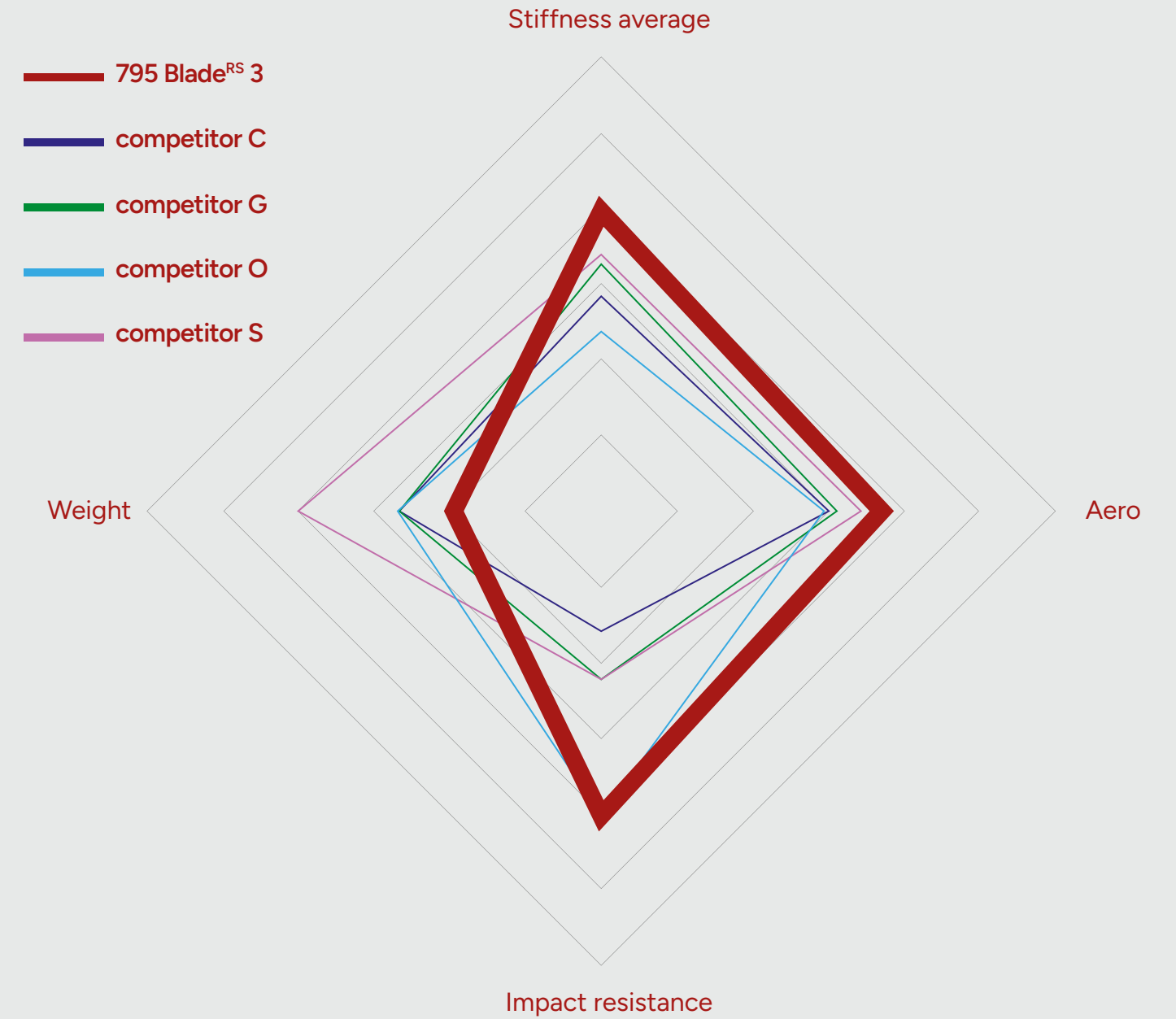

A close-up, low-angle shot of a bicycle handlebar. The handlebar is dark grey or black with a prominent red stripe running horizontally across its width. The central part of the handlebar, where it connects to the stem, is more complex and has a curved, ergonomic shape. The word "LOOK" is embossed on the top surface of this central section. The background is dark and out of focus, showing parts of the bike's frame and other components.

NEW

Aero Carbon^{RS} 3 Bars.

The game changing design of the new Aero Carbon^{RS} 3 handlebars is the key improvement to help you go faster. Not only did we reduce drastically its aero drag, but we also developed an ergonomic shape that helps the rider to stabilize the aero position, optimize power transfer and offers a perfect position for climbing.

Our mission here was to ensure that the aero improvements provided by the 795 Blade^{RS} 3 are working in synergy with the rider, increasing the benefit of a reduced aero drag by staying in position longer when the opponents must change theirs.



Breakaway

Revolutionary shape designed to hold the aero position longer than the competition with a more relaxed upper body.



Sprint

Stiffness and fast hands movement in the drops to deliver maximum power.



Climbs

Sweep and flare of the bars unlocks chest and shoulders for a better breathing and perfect handling.



Our know how is to define the right mix of fibers, resins and layups to get the right stiffness, weight and responsiveness.

For LOOK 795 Blade^{RS} 3 standards, our frames comply with ISO 4210, which defines the safety requirements applicable to bicycles. Fatigue tests are carried out using load cases increased to 110%, and up to 160% for impact tests. We also apply additional internal standards (LOOK standards), which cover test configurations and loading cases not included in the standard industry test.

The result : a bike that follows you for life.



AT COMPETITIVE AMATEUR PACE

*For an equivalent time of 8h08
on the LIÈGE-BASTOGNE-LIÈGE CHALLENGE
ridden at 31kph average*

The **795 Blade^{RS} 3** would help you achieve that result with a **180W** power average, **7W** less than the previous generation for the same speed.

To achieve the same result with the previous **795 Blade^{RS}**, your FTP would need to be **11W** higher (**+3.9%**).

AT PRO RACE PACE

*On Stage 19 of the TOUR DE FRANCE 2026
GAP (HAUTES-ALPES) - LE BOURG-D'OISANS (ISÈRE)
(128 km - D+3500m)*

2'27"

Gained between the current **795 Blade^{RS}**
and the **795 Blade^{RS} 3**.

Gains You Can Feel At Every Level.

For the pros: the high-speed flat and rolling stages where watts decide the day.

For you: the fast Sunday bunch, the cyclosporitive, the spring-classics terrain where a wheel saved is a place gained. Same bike, same gains.

Part 1

Real-World Gains

Part 2

Custom Performance

350 ways to be faster.

Your bike, your rules.

Stem, stack, bars, seatpost; 350 fit combinations mean the **795 Blade^{RS} 3** adapts to your body, your style, your ambitions, not the other way around.

Open the configurator and make it yours down to the detail: paint, groupset, wheels. Dial it in once, ride it tuned in forever : the position you hold at km 10 is the position you hold at the line.

This is performance, tailored.

Part 3

Unique Riding Experience

HIGH AND BALANCED

Aeropost 5 : 27 mm Offset

Aero Carbon Combo Stem : 80 mm

Stack : +50 mm



Engineered To Fit. Designed To Feel.

Going faster starts with you. A wide choice of bar widths, seven stem lengths, 0–50 mm of headset spacers and two seatpost offsets give you the freedom to dial in your position precisely - all through our configurator.

The result: a finely tuned fit that maximises your aero gain, sharpens pedalling efficiency and keeps the same handling character from XXS to XL.

350

Possible Settings

LOW AND FORWARD

Aeropost 5 : 0 mm Offset

Aero Carbon Combo Stem : 140 mm

Stack : +0 mm



Aeropost 5 **NEW**

27

0



With offset
+42 ↔ -8

Without offset
+15 ↔ -35

Aero Carbon^{RS} 3 Bars **NEW**



0-50mm
Headset spacers
(5 or 10)

380 / 400 / 420

360 / 440
Compatible with the previous version
Aero Combo Carbon Handlebar

Aero Carbon Stem

80 / 90 / 100 / 110 / 120 / 130 / 140

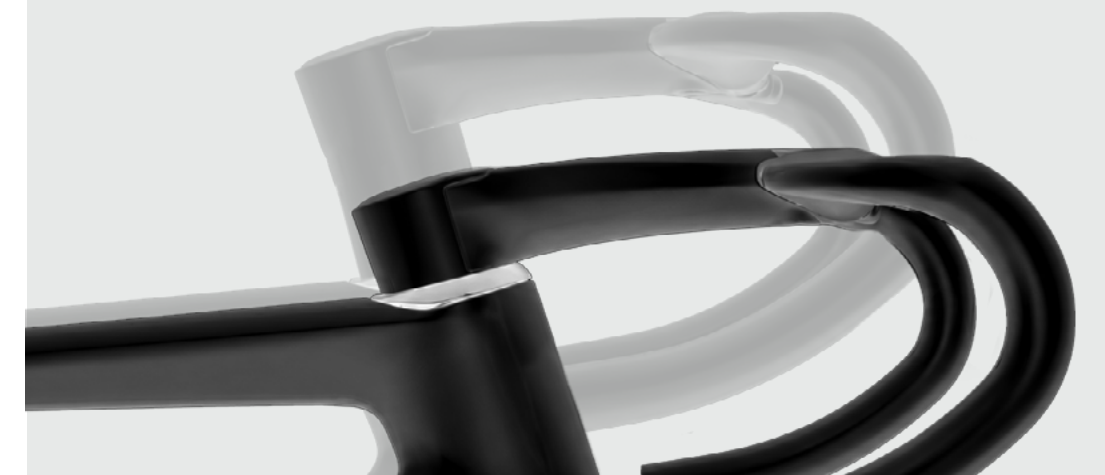



The 795 Blade^{RS} 3 is a new beginning for Look. The successful responsiveness and maneuverability of the previous generation is there – and even slightly improved – with a completely overhauled aerodynamic and composites technical foundation.

The aerodynamic performance has been developed with research labs and has been crafted for real world conditions: high yaw angles, unsteady air, and turbulence caused by the cyclist around the legs. These conditions are all the bike will ever see at speeds between 30kph and 40kph. With the 795 Blade^{RS} 3, we are very happy to offer our best performance package ever, for pros and amateurs alike.

Charles PHILIPPE
R&D Manager
LOOK Cycle



As a team, we managed to find the right engineering tradeoffs and give a strong identity to the bike, by widely addressing ergonomics through the numerous fitting options and the handlebar's innovative geometry.

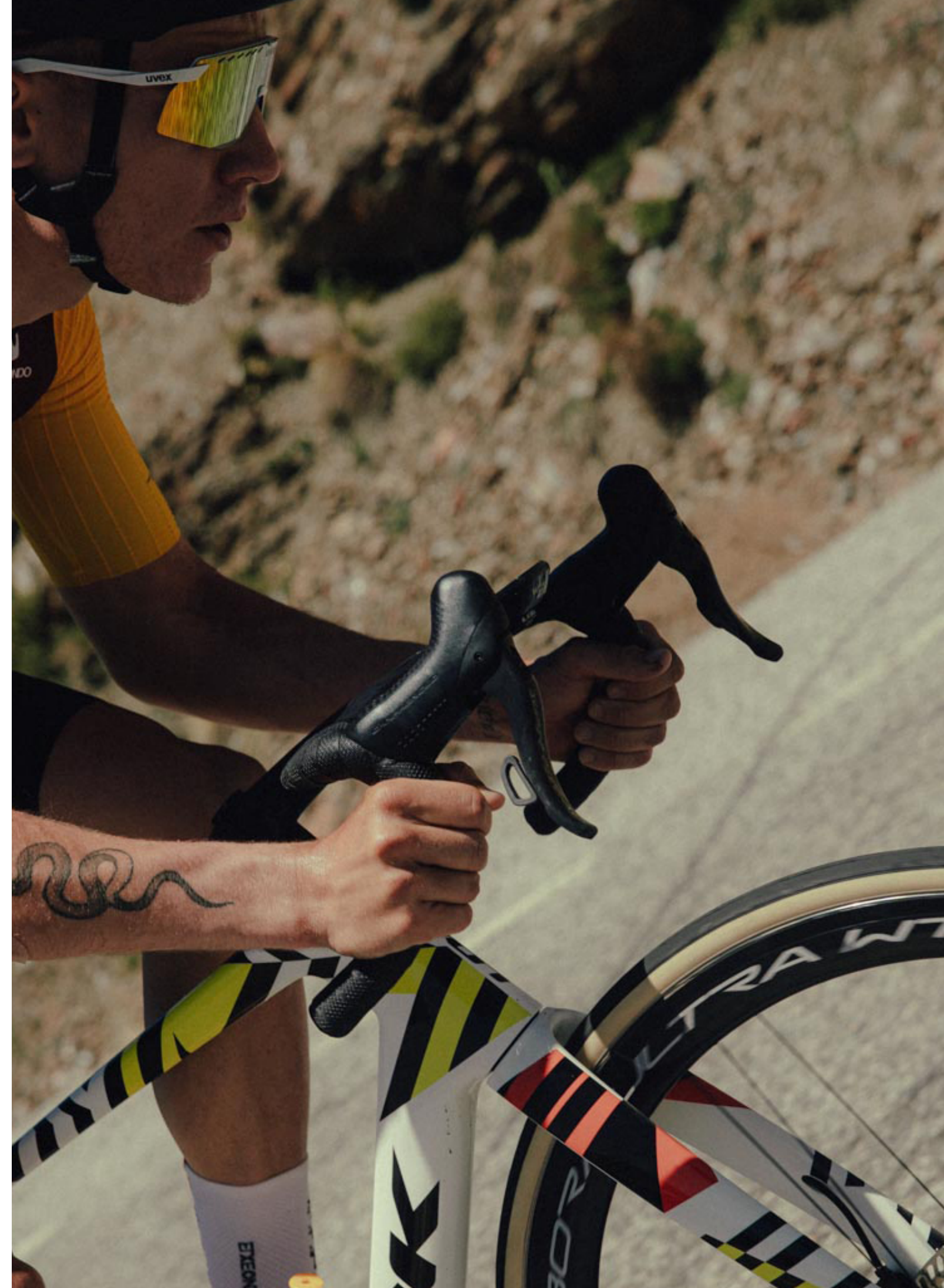

Reach/Stack Mapping by Frame Size

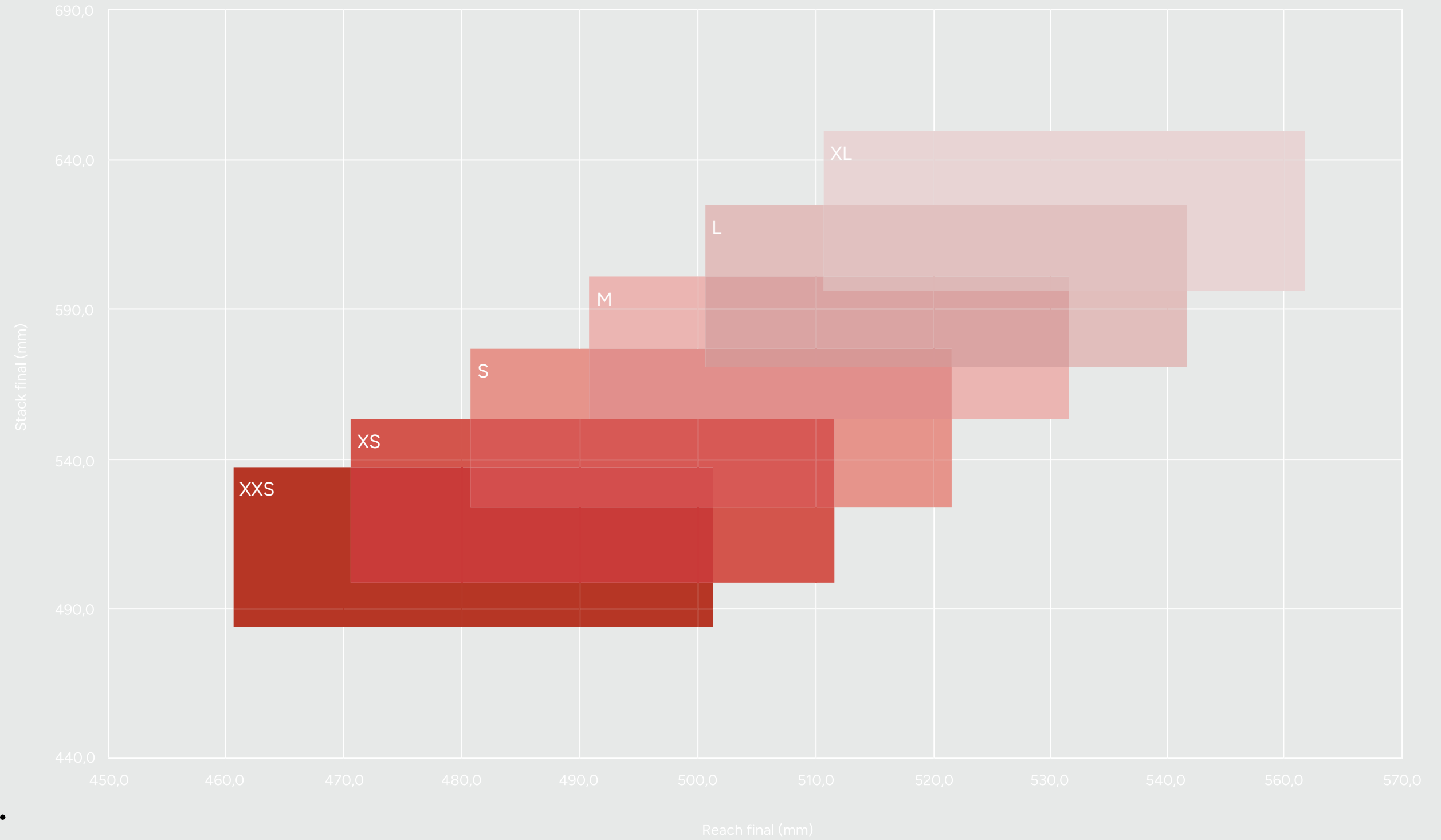

Development Of Geometries.

Our smart geometry development covers a wide range of cyclist profiles.

Not only can the bike fit riders from 155 to 200cm but each rider can be confident in finding the right fit, Having the choice between 2 sizes or more to adapt to their style and fitting requirements.

Hundreds of combination between frame size and components are key to dial your position perfectly.

Reach/Stack Mapping by Frame Size

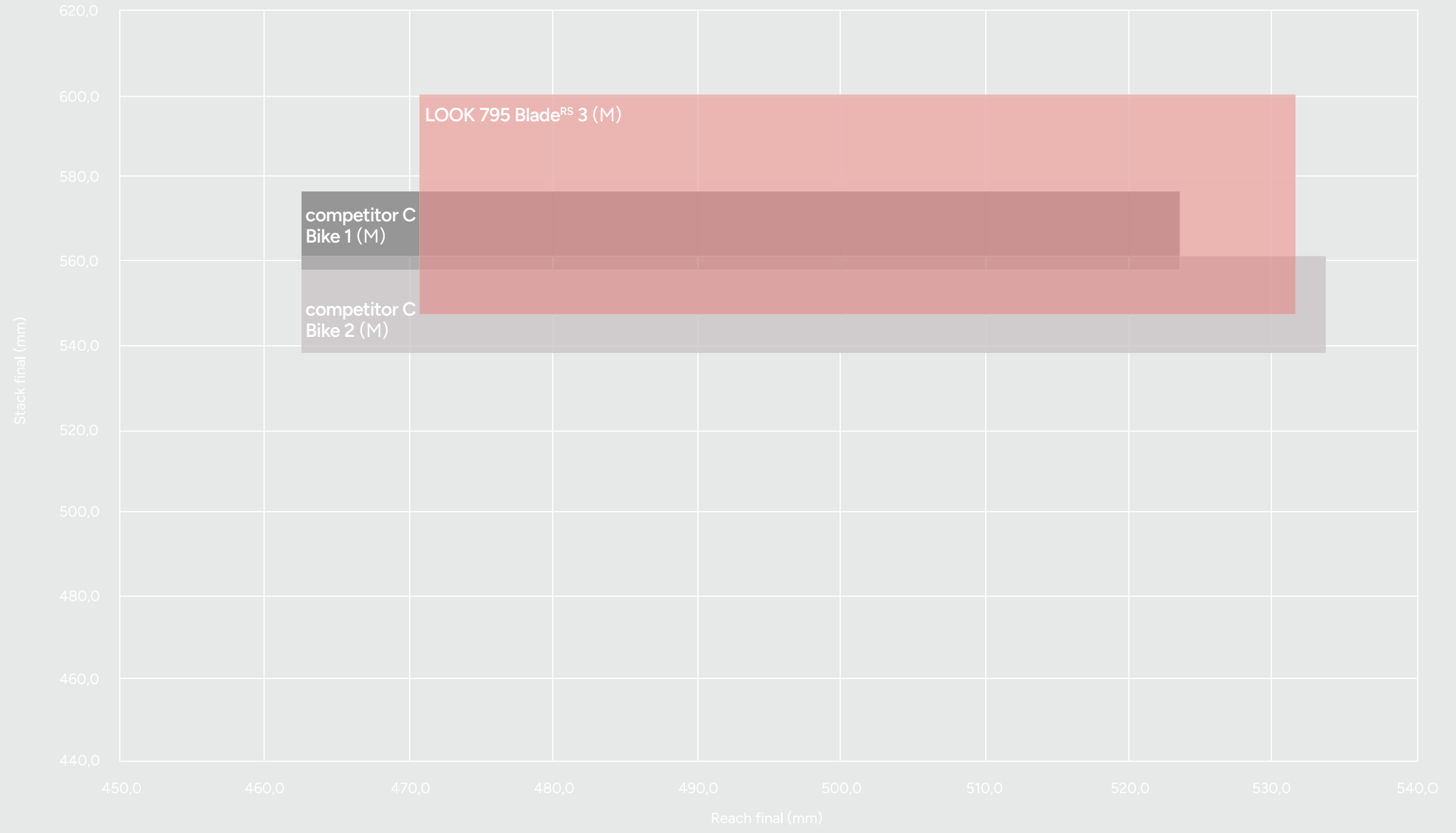

The **795 Blade^{RS} 3** was designed to adapt, not to constrain.

Its reach and stack fitting range covers an amplitude that competitors only achieve by combining two distinct platforms.

Whatever their morphological profile, the rider will find their optimal position on this bike.

6 Sizes

6 Geometries

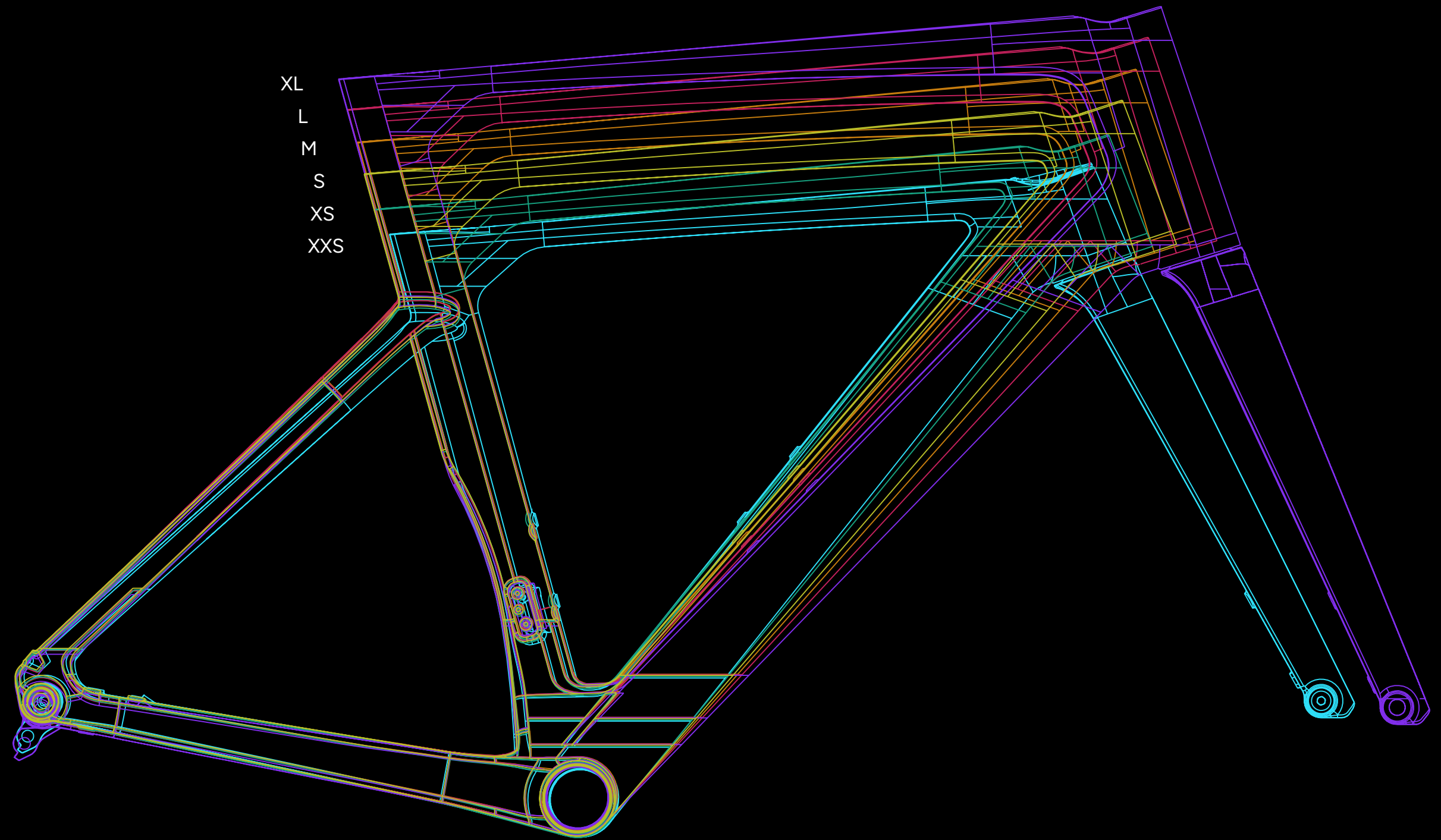

Not Duplicated, Crafted.

The geometry of the 795 Blade^{RS} 3 is developed size by size, each with the same performance-seeking spirit, so every rider gets the same benefit.

A woman riding XXS gets a frame engineered for her, not a shrunk version of someone else's.

The three fork offsets ensure the same handling personality from XXS to XL.

When the easy path is to scale one mould, we craft every size.

795 Blade^{RS}



NEW 795 Blade^{RS} 3

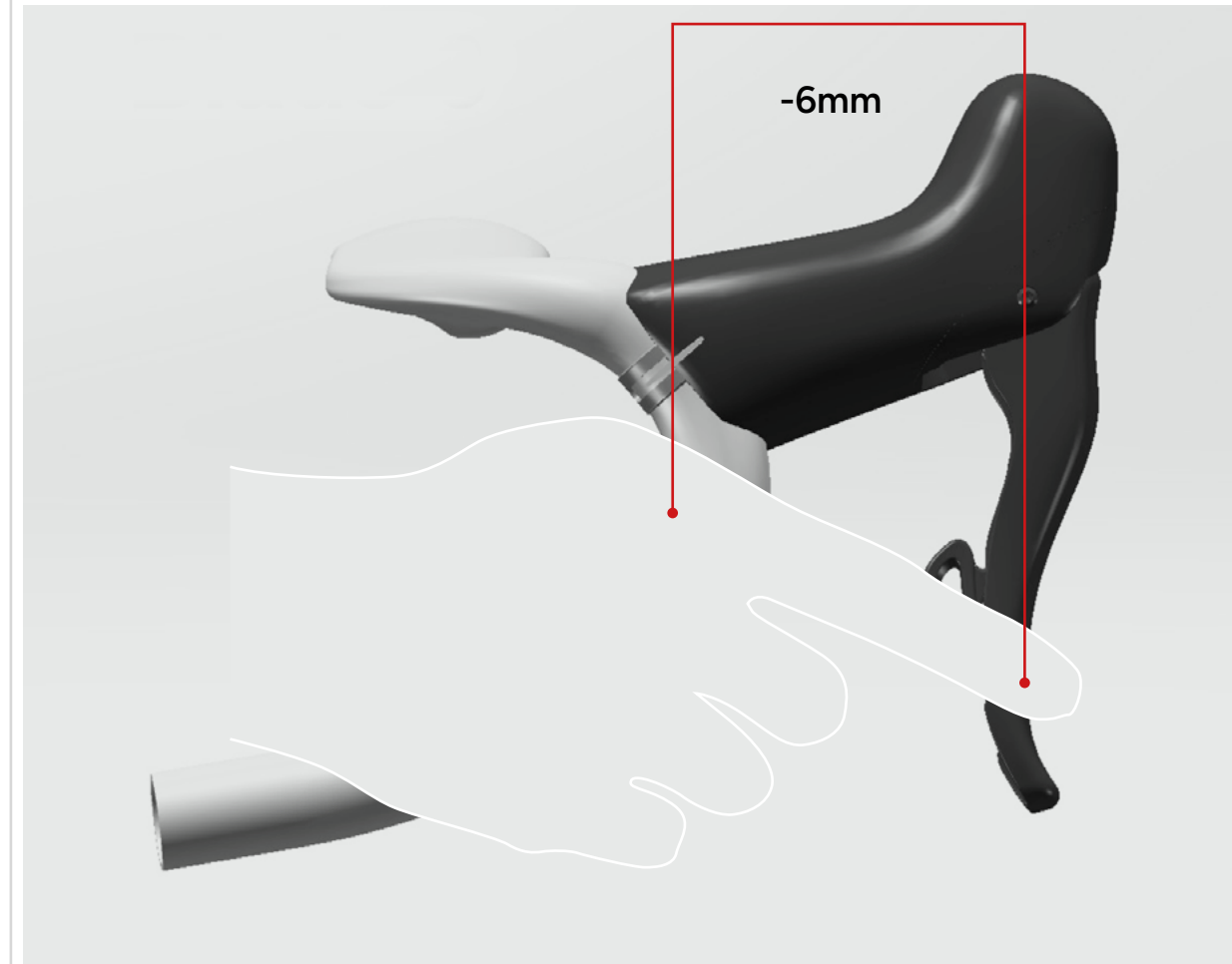
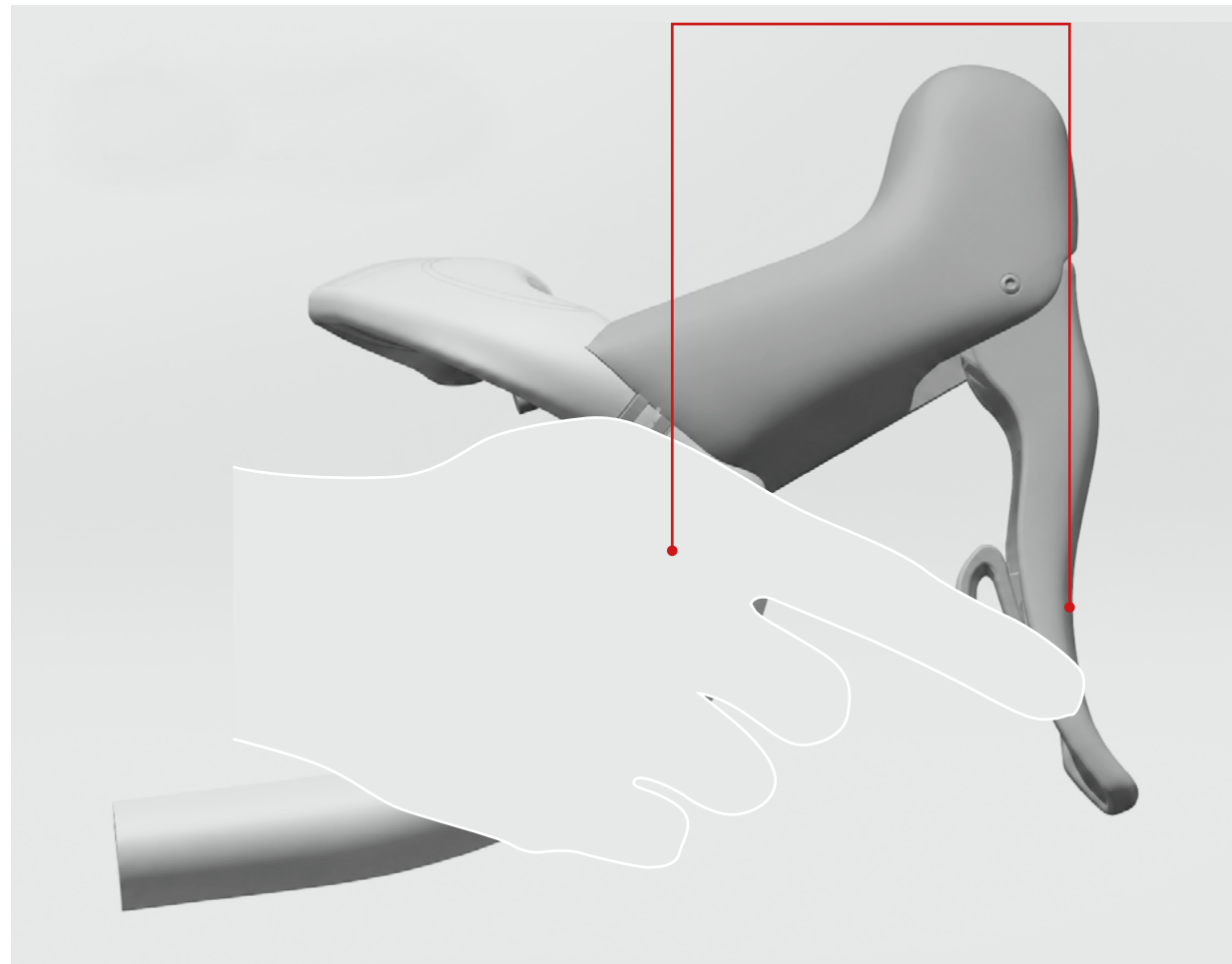

Silver Red



Pro Team Black



Iconic Prisme



Orange Shift



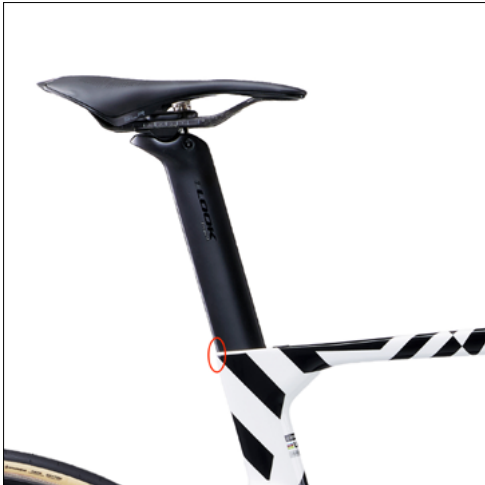

Seatpost

Aero Post 5
With offset
Without offset



Cockpit

Aero Carbon^{RS} 3 HB
380
400
420

Color

Iconic Prisme
Pro Team Black Raw
Silver Red
Orange shift / Black

Size

XXS
XS
S
M
L
XL



Aero Carbon Combo Stem
80
90
100
110
120
130
140



Groupset

SHIMANO Ultegra Di2 2X12
SHIMANO Dura-Ace Di2 2X12
SRAM Force E1 AXS 2X12 **NEW**
CAMPAGNOLO Super Record 2X13



Wheels

LOOK R45S
MAVIC Comete 50 **NEW**
FULCRUM Speed 57
SCOPE Artech 6.A **NEW**

Part 1

Real-World Gains

Part 2

Custom Performance

Part 3

Unique Riding Experience

The unique geometry of the **795 Blade^{RS} 3** is born from years of reflexion around what makes a great ride.

Beyond speed and efficiency, LOOK bikes are offering character, and a singular ride feel made of precision, stiffness and supreme handling.

By giving every size the same level of care and meticulously validating our frames and components, LOOK puts the rider first, aiming to deliver the joy of every ride on a **795 Blade^{RS} 3**.



Romain SIMON
Bike Category Leader
LOOK Cycle

The 795 Blade^{RS} 3 was designed with a simple philosophy: real gains. For this new version of our racing bike, the major performance changes build on the previous generations: aerodynamics at the highest level, and a weight-to-power-transfer ratio optimized for the demands of racing.



Our conviction: developing bikes with high technical promise and countless marginal gains only has value if the bike fits the riders perfectly and gives them the finest emotions on the bike.

The promises of this new model are both simple and ambitious: tangible benefits on the road for every rider, through an ergonomics and adjustability that let you position yourself perfectly; a unique riding experience made of character and precision; and the standards of French high-end craftsmanship.

Painted and assembled in the LOOK manufacture in Burgundy, guaranteed for life, and built to meet the demands of professional teams and passionate riders alike, the 795 Blade^{RS} 3 is the expression of the historic savoir-faire of our brand - a pioneer of competitive cycling.



Where Art Meets The Road.

The 795 Blade^{RS} 3 is painted, assembled and quality-controlled in our «Maison» LOOK in Burgundy, France.

A handcrafted expression of performance, carrying French savoir-faire and 40 years of road-racing legacy.

Delivered with a carbon owner's card that certifies the frame is yours.

Crafted In Burgundy

Excellence

Craftsmanship

French spirit



Lifetime warranty

under registration for frame and fork.



Delivered with a carbon card owner certificate.



Painted and assembled
in our «Maison» LOOK
in France

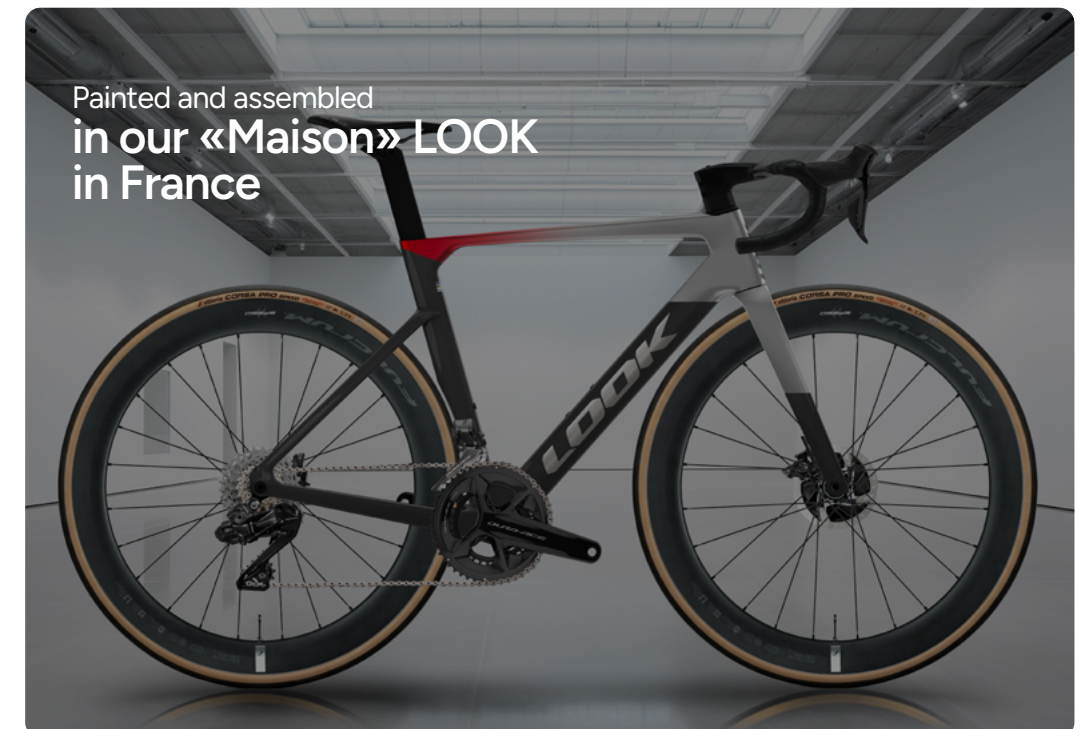

Since the 795 generation, LOOK has been refining the synergy between stiffness and geometry.

Today, the convergence of these two elements is the magic formula behind a riding experience unlike any other on the market.

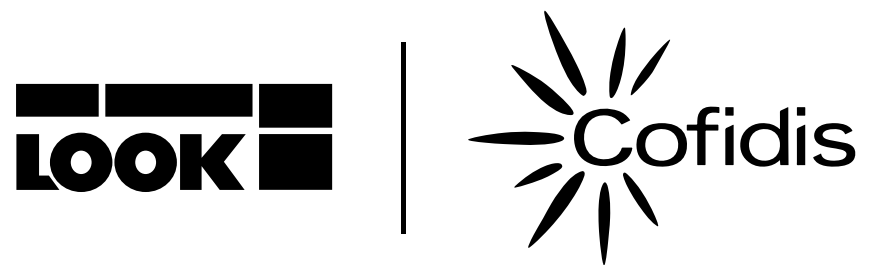

Same Bike. No Exception.

One LOOK principle has never wavered: you ride the exact same bike as the pros.

The **795 Blade^{RS} 3** is no exception. Developed from the first sketch and raced undercover for months with the women and men of Team Cofidis, it took a stage win at Itzulia Basque Country before you ever heard its name.

Since 2023, riders have won on the stock **795 Blade** across every kind of race - proof that what wins for them is what we hand to you.

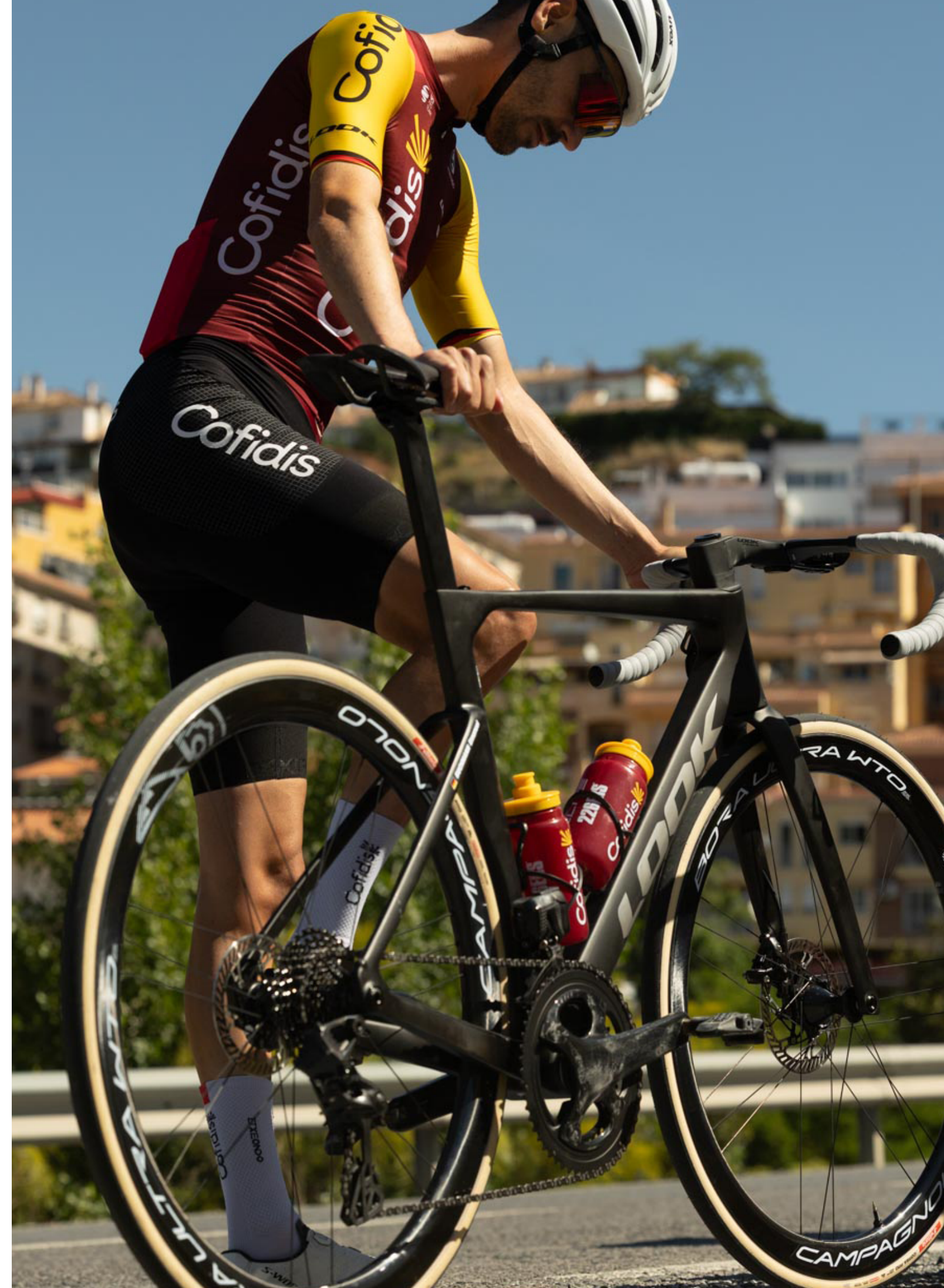

Contact

Jon Denham
Senior PR Executive
jon.denham@shiftactivemedia.com
M: +44 (0) 783 455 7783

**SHIFT
ACTIVE
MEDIA**

30 Monmouth St, Bath, BA1 2AP, UK